

BEST TIPS

FOR PROCESS SIMULATION

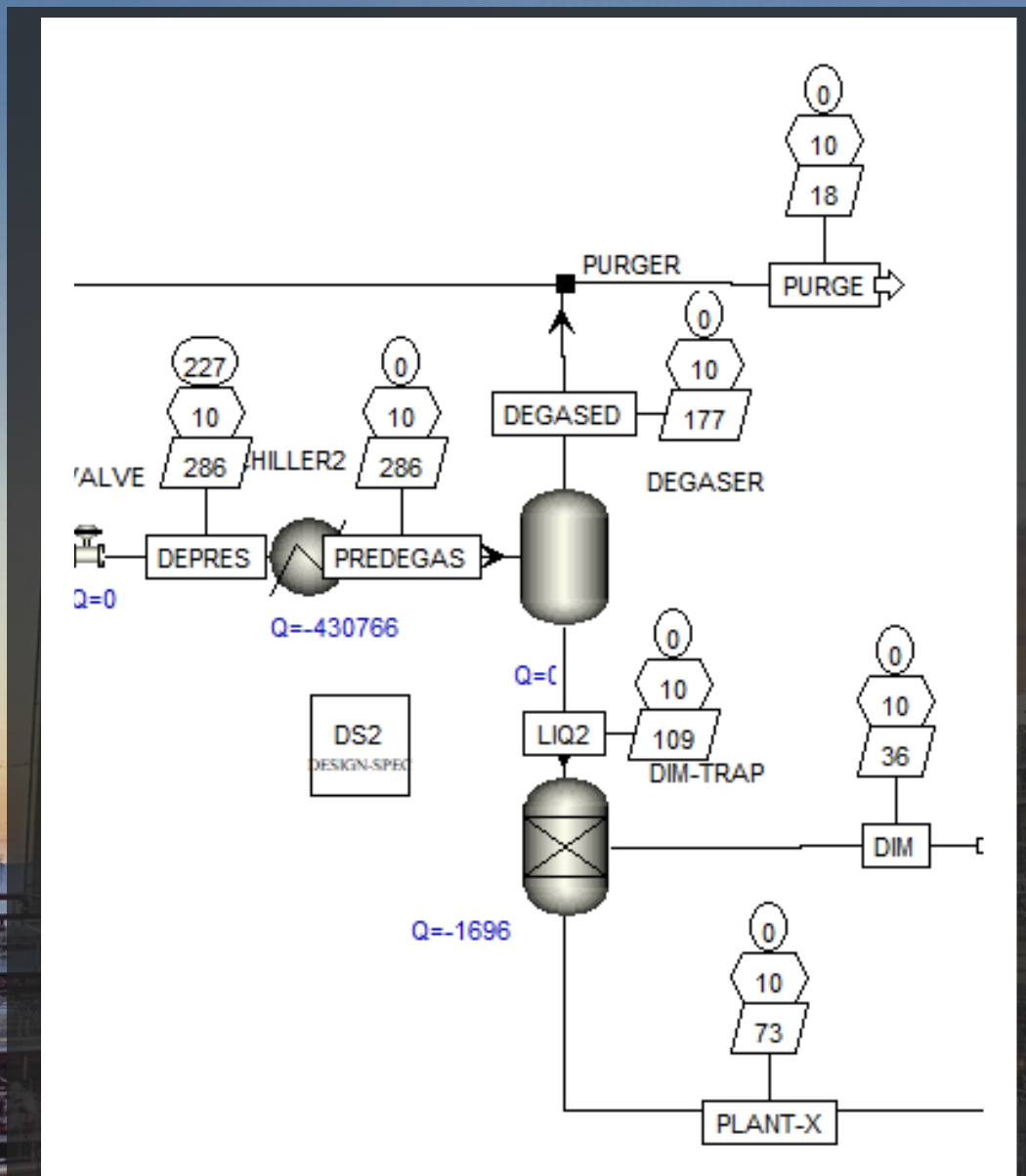

BY CHEMICAL ENGINEERING GUY
AKA EMMANUEL ORTEGA



TIPS

01 DISPLAY T/P/F LABELS

Adding temperature, pressure flow, heat duties and other interesting labels in the flowsheet

02 ADD A TABLE OF RESULTS

Adding a table of results might facilitate study of the process

03 FORMAT FLOWSHEET

Formatting the flowsheet is one of the most important parts, specially when presenting to other colleagues. Color and visuals are important too!

04 GETTING HELP ONLINE

The best way to get help in your Simulation? Join us in the Forum!

05 USEFUL SHORTCUTS

Don't spend time in searching for buttons and commands! Use your time wisely! Use shortcuts!



06 HIERARCHY LEVELS

Have a repeating process? Why not use the hierarchy block. Save time and simplicity in the process simulation!

07 PLOT, PLOT, PLOT!

FPE = F*cking Plot everything. Plots literally will open a new VISUAL panorama for you to analyse further in the process!

08 EXPORT TO EXCEL

We all have a love-hate relationship with Excel, but we know we couldn't live without it! Learn to use it with Aspen!



09 SENSITIVITY ANALYSIS

Ever wonder what will happen if we change gradually a variable? Well... this is your best friend then!

10 BE PATIENT!

LEARNING = TIME
TIME = PATIENCE



TIPS

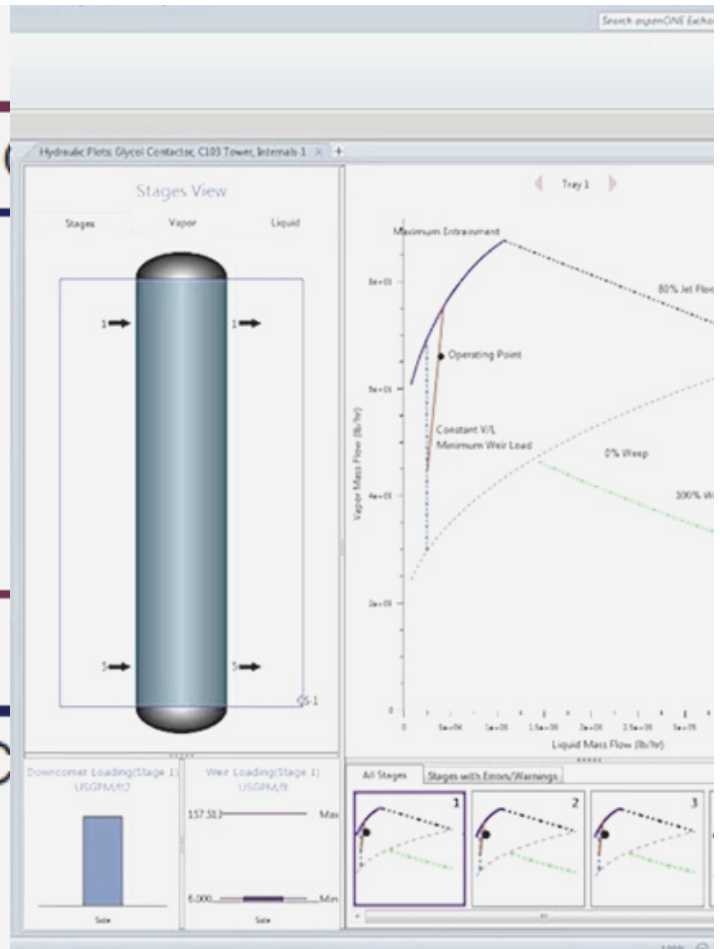
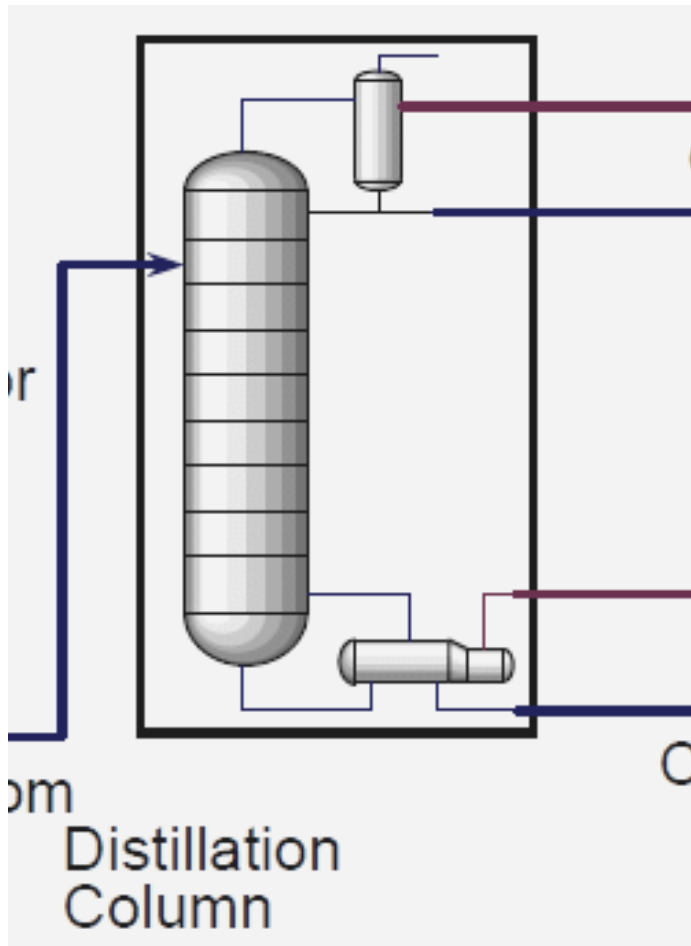

ABOUT THIS E-BOOK

WRITTEN EMMANUEL ORTEGA

Hey there! I'm happy you decided to pump up your Process Simulations skills!

In this small E-book we will learn basic tips that will improve **your simulation technique and save you lot of time, effort and tears**

The tips are not related between each other, so you can just skip to the desired tip.

Most of these tips are taught in my courses, so feel free to **join us** anytime!

JOIN US!



ABOUT THE AUTHOR

EMMANUEL ORTEGA

AKA

CHEMICAL ENGINEERING GUY

I am a Chemical Engineer with a minor in Industrial Engineering, graduated in 2012 (ITESM in Monterrey, Mexico)

As a young Engineer, I used to work in Plant Simulation Processes in INEOS KOLN, Germany. Mostly hydrocarbon systems, Naphtha treating and byproduct separations.

In Mexico, I worked as a Process Engineer in charge of Polymerization, Extrusion and Textile Yarn Production (PET)



Since the last few years:

I decided to take the educational path specifically Process & Chemical Engineering & Process Simulation, and tutoring ... all this ...

ONLINE!

Let's begin!

Contact me: [Hello@ChemicalEngineeringGuy.com](mailto>Hello@ChemicalEngineeringGuy.com)



TIP 01 - DISPLAY T/P/F

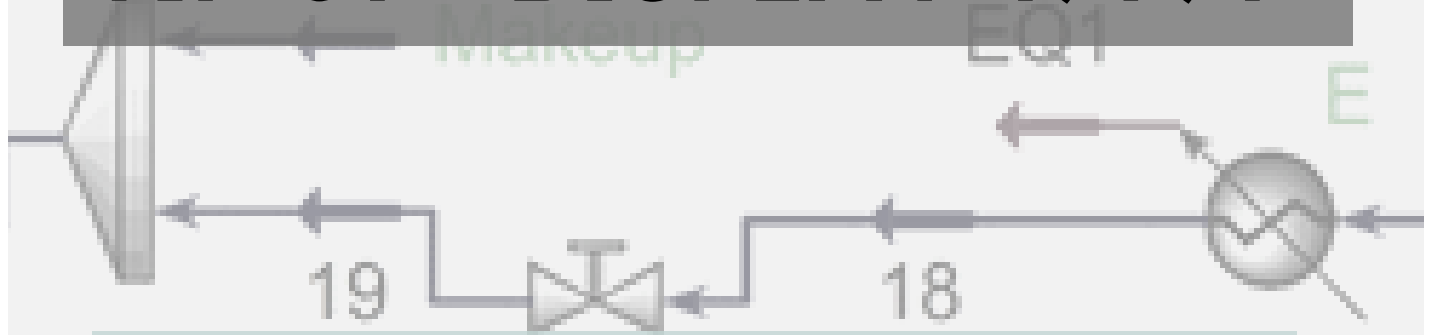

Don't you hate to open the results to verify just a single Temperature in a stream?

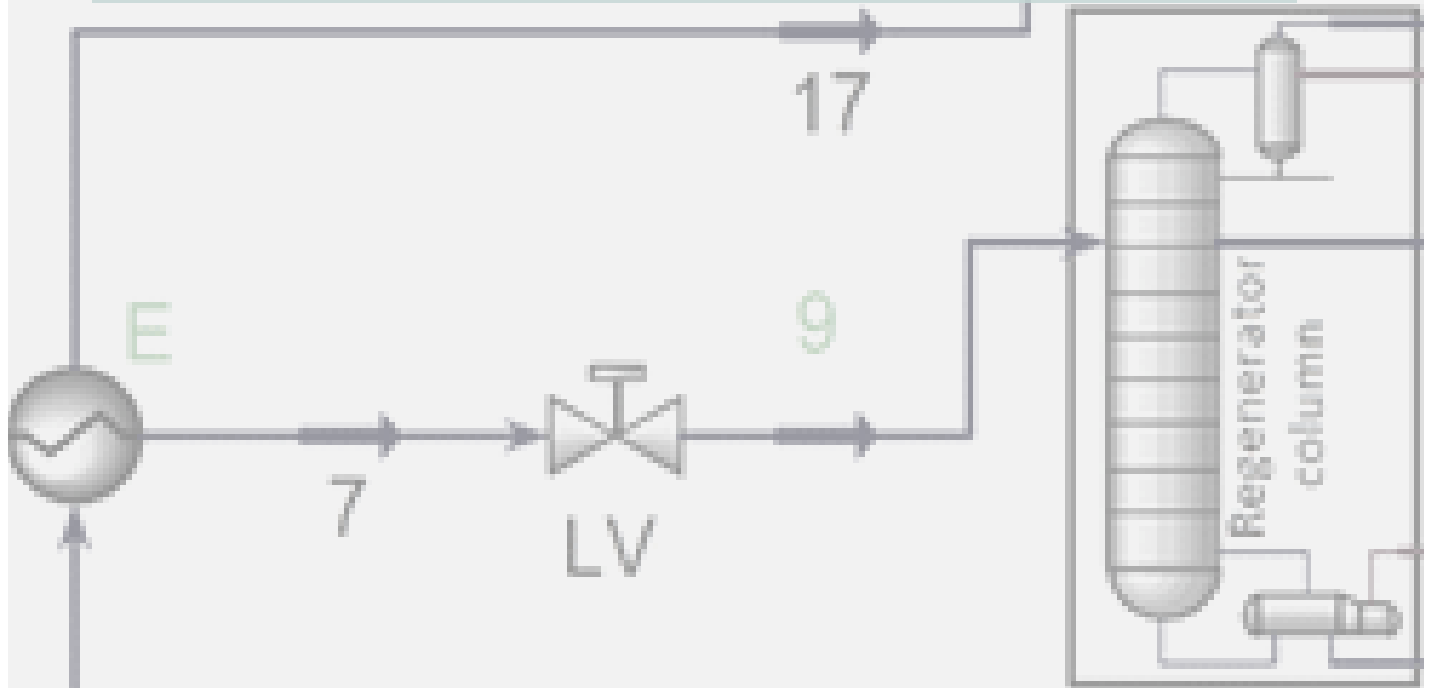

Or Opening the workbook / table results just to verify a flow rate?

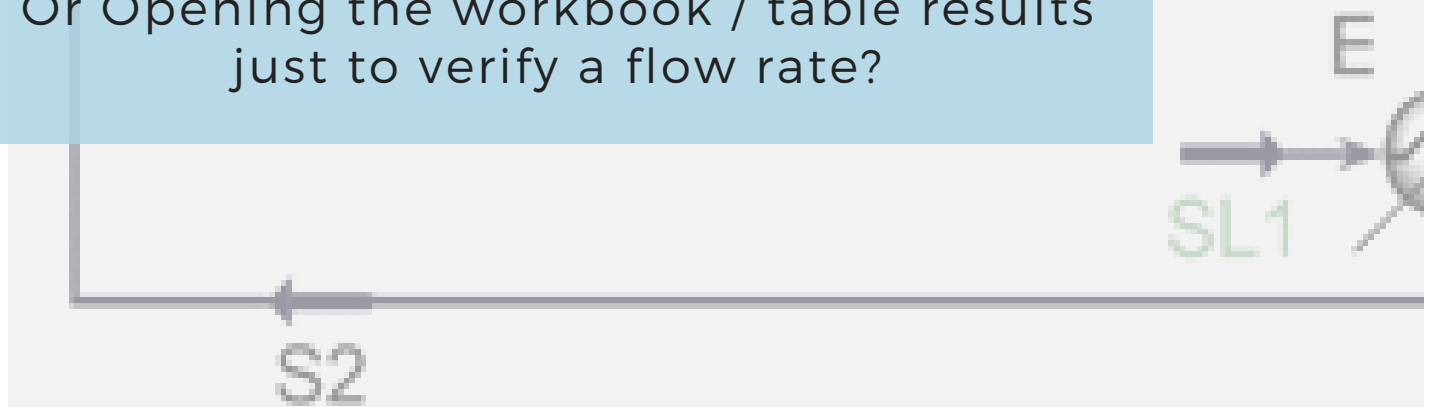

SIMPLIFY YOUR LIFE!

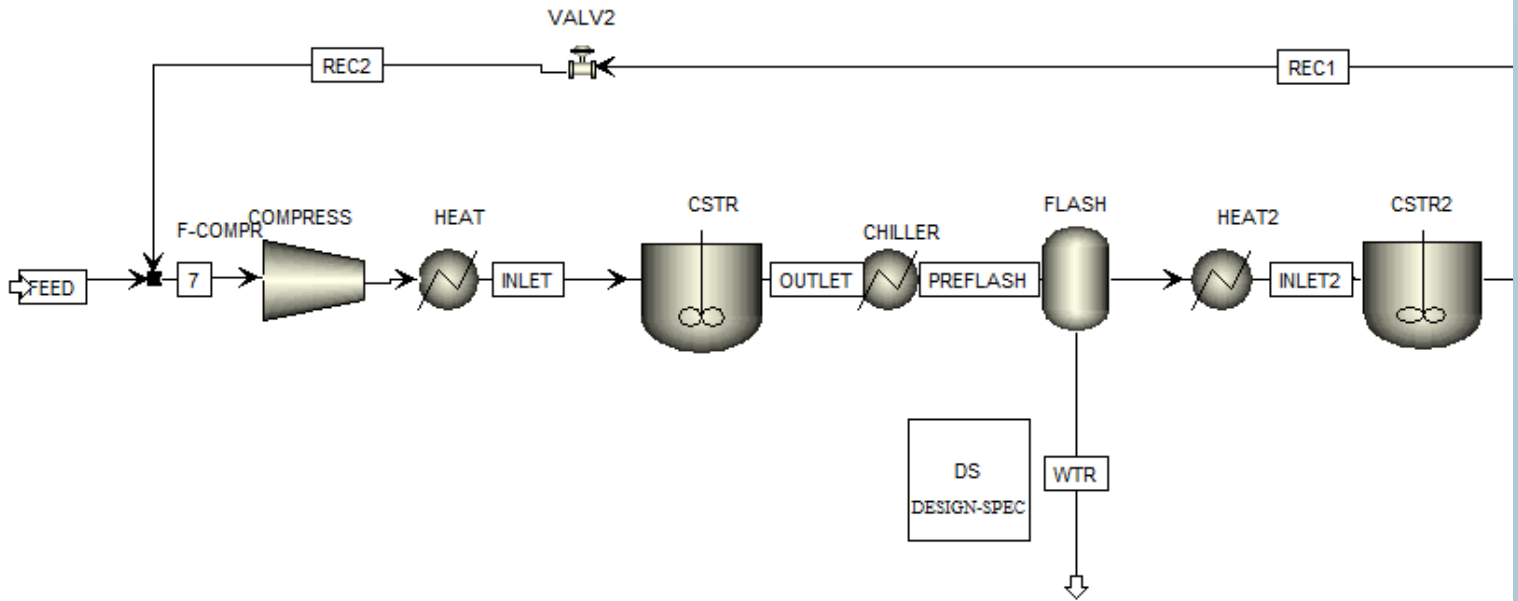

Mole or Mass:
even Volumetric Flow

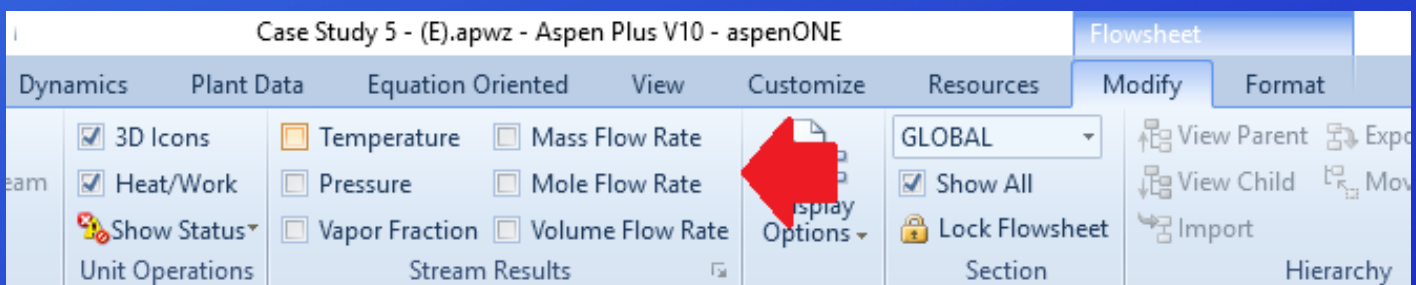

Get more in this Course!

SIMPLIFY YOUR LIFE!

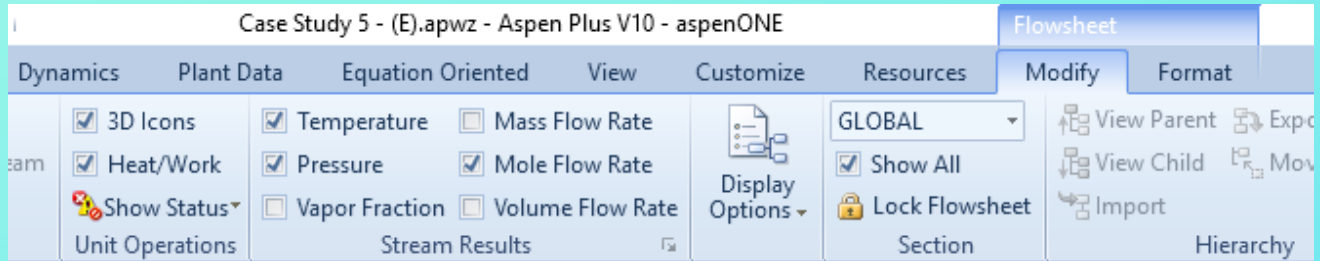

Select Required!

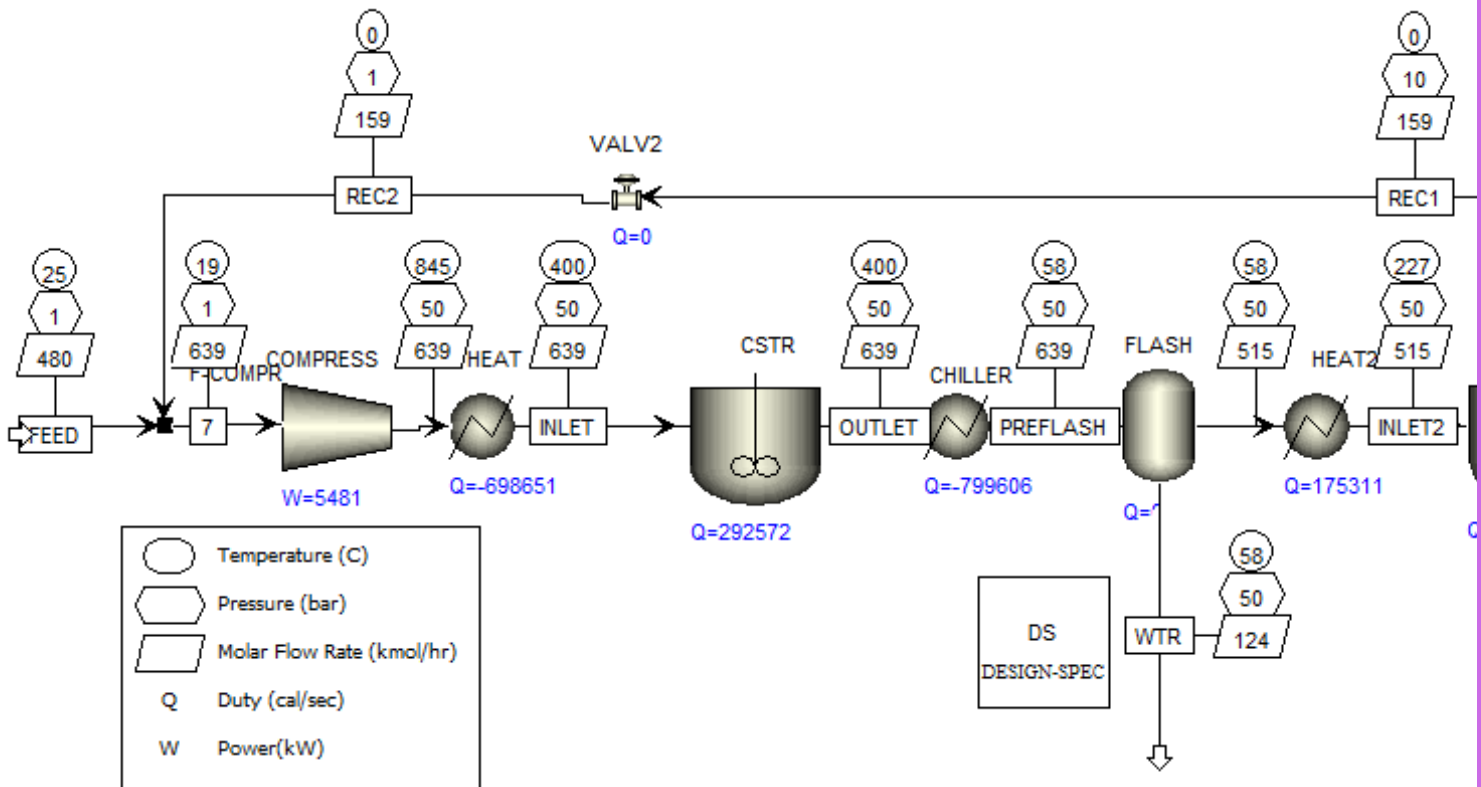

Also Work & Heat duty!

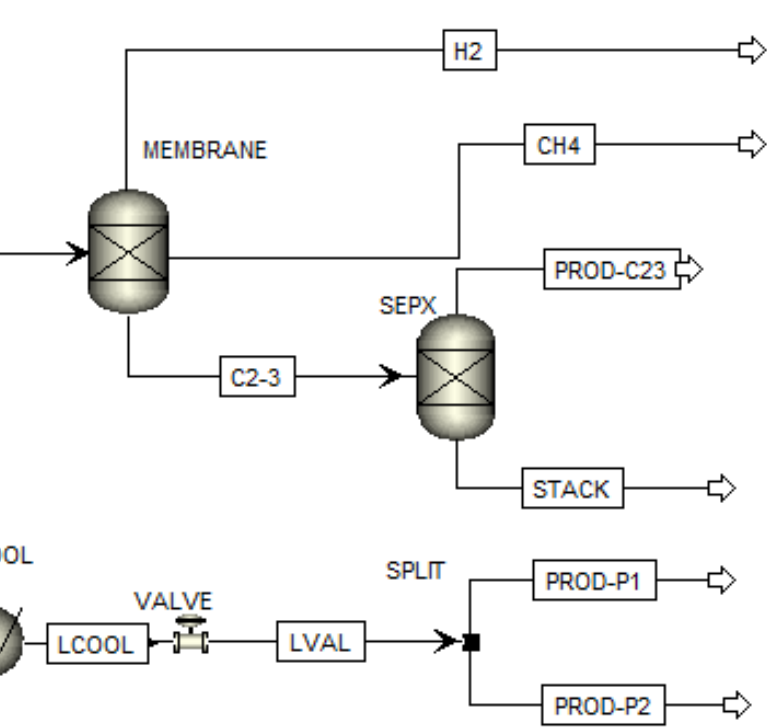

TIP 2 - TABLE OF RESULTS

Adding a Table of Results is recommended specially when running the simulation directly in the flowsheet.

The results will be updated depending on the given data.

Also convenient for printing and screenshots

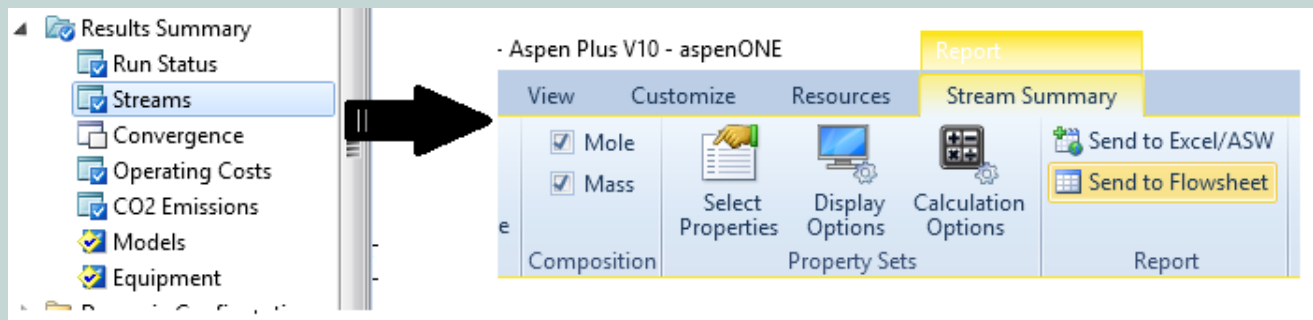

Stream	Phase	Temp (C)	Pressure (bar)	Flow (kg/hr)	...
MEMBRANE	MEMBRANE	MEMBRANE	MEMBRANE	MEMBRANE	MEMBRANE
SEPX	SEPX	SEPX	SEPX	SEPX	SEPX
PROD-C23	PROD-C23	PROD-C23	PROD-C23	PROD-C23	PROD-C23
PROD-P1	PROD-P1	PROD-P1	PROD-P1	PROD-P1	PROD-P1
PROD-P2	PROD-P2	PROD-P2	PROD-P2	PROD-P2	PROD-P2
STACK	STACK	STACK	STACK	STACK	STACK
VALVE	VALVE	VALVE	VALVE	VALVE	VALVE
LCOOL	LCOOL	LCOOL	LCOOL	LCOOL	LCOOL
LVAL	LVAL	LVAL	LVAL	LVAL	LVAL

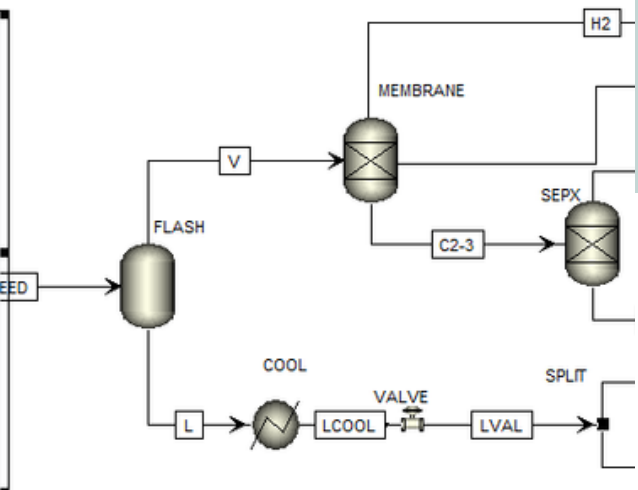



”

***VISUAL IS
EVERYTHING
WHEN
PRESENTING***

“

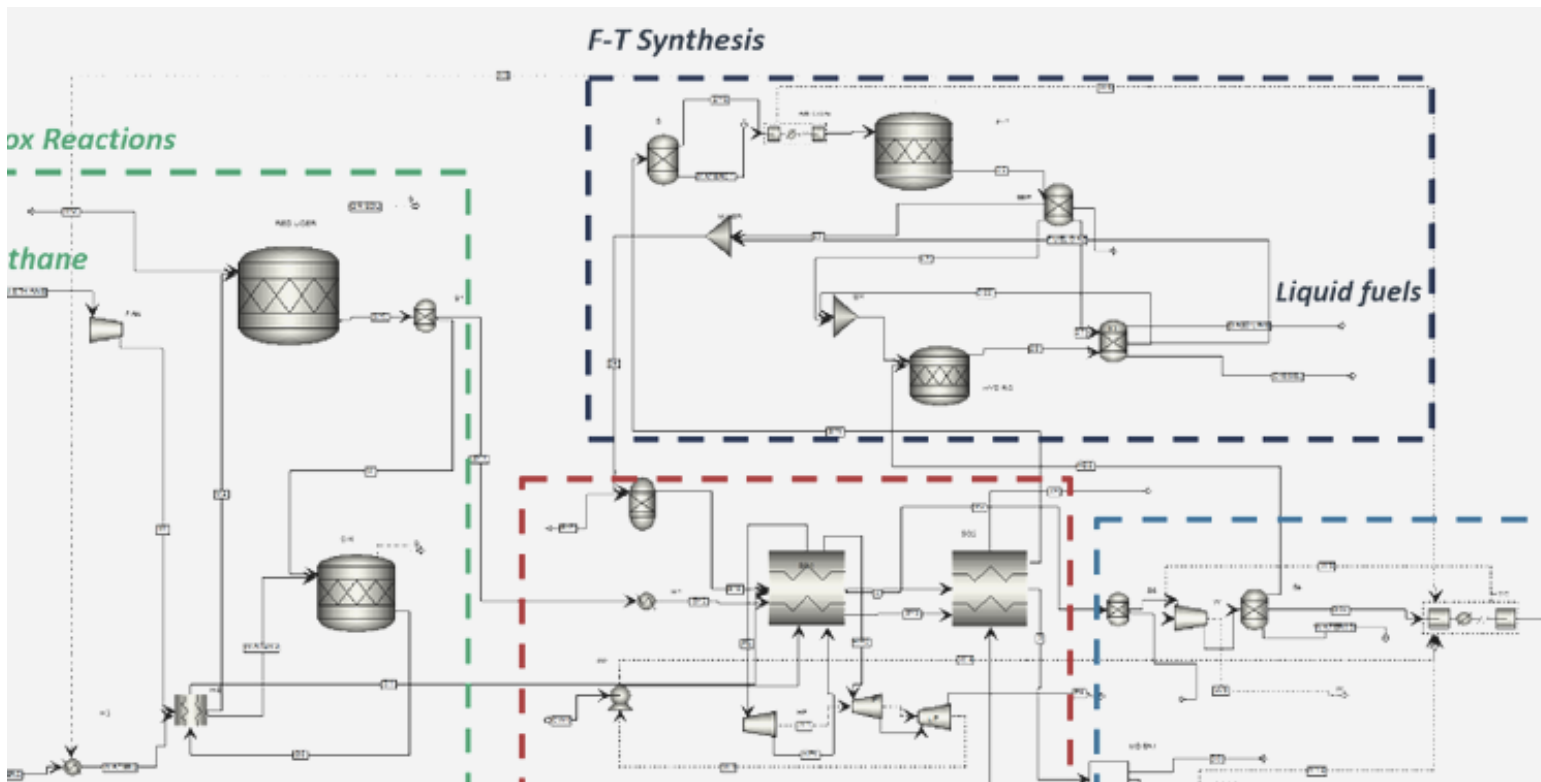

TIP 3 - FORMAT YOUR FLOWSHEET!

Use rectangle to denote:

- Reaction Area
- Heating/Cooling Zones
- Product Lines
- Compression Areas

YES, EVEN JUST FOR YOU!

Use Colored Lines for:

- Raw Materials
- Final Product
- Track Catalyst
- "HOT" Streams
- "COLD" Streams

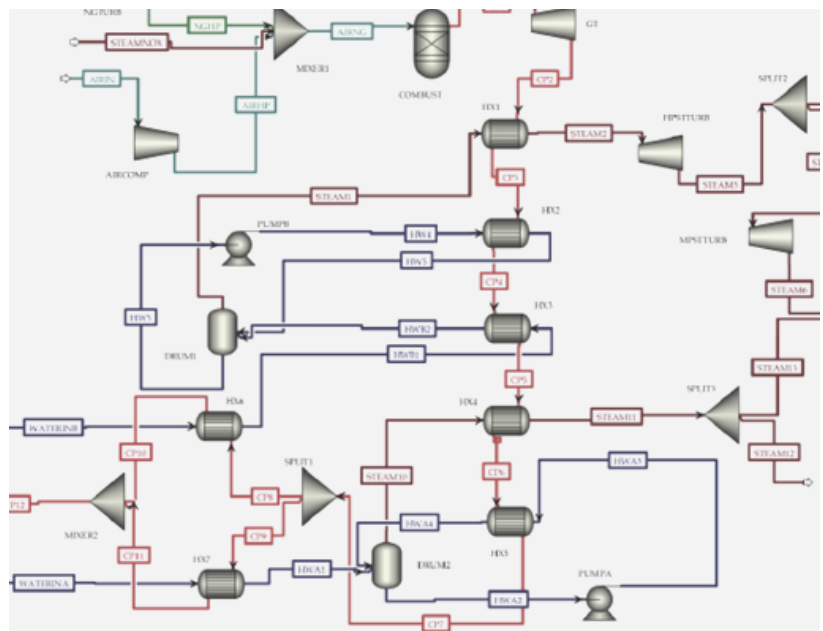

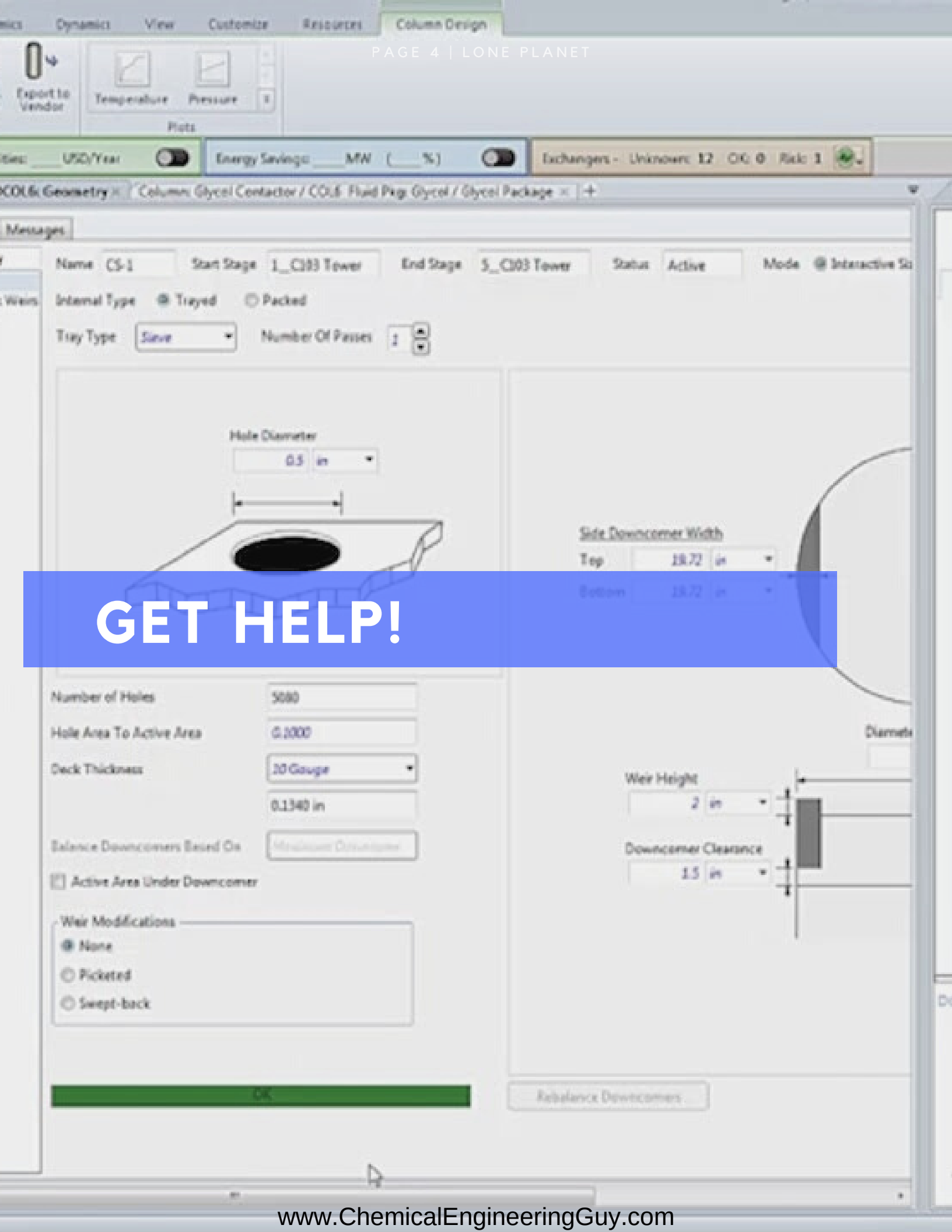

GET HELP!

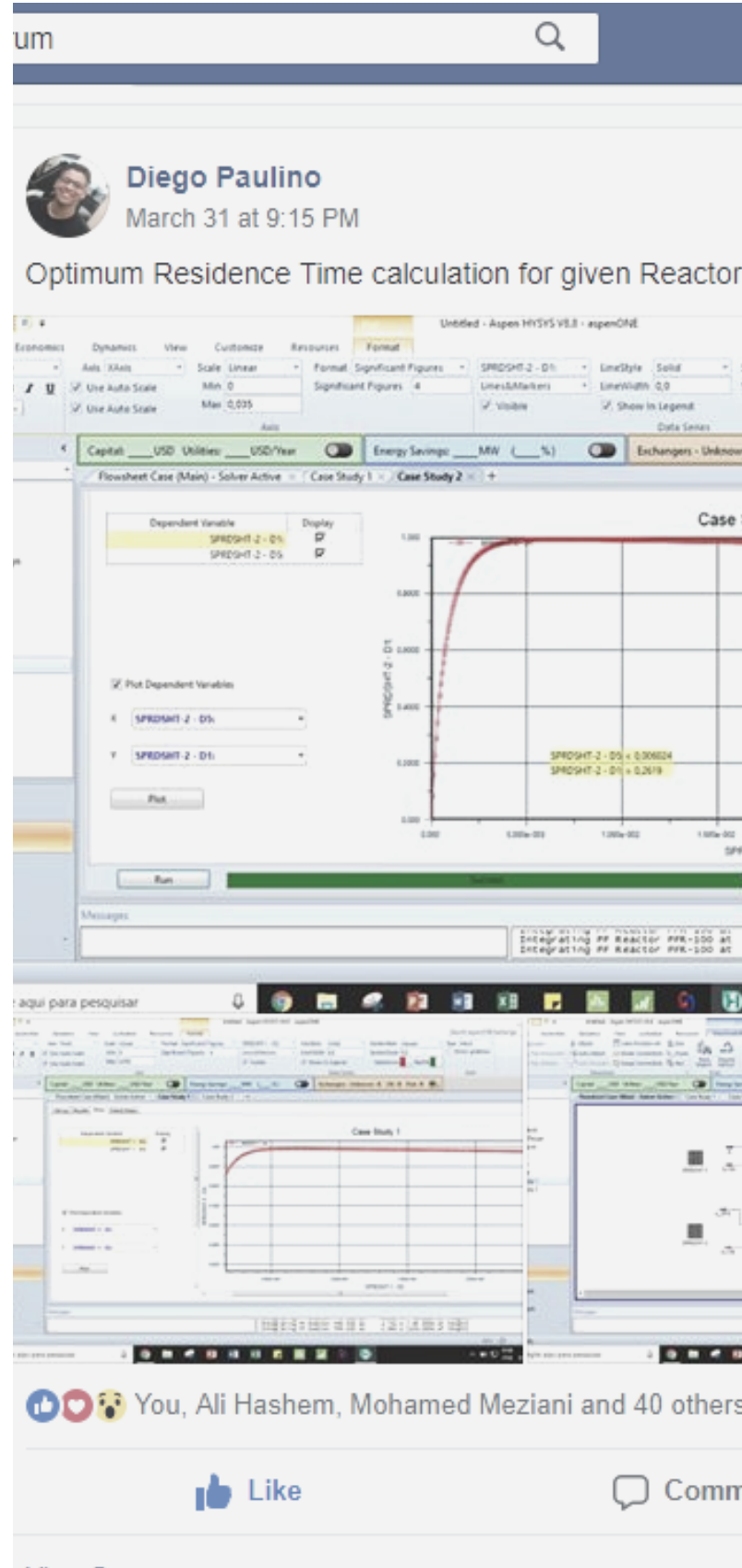
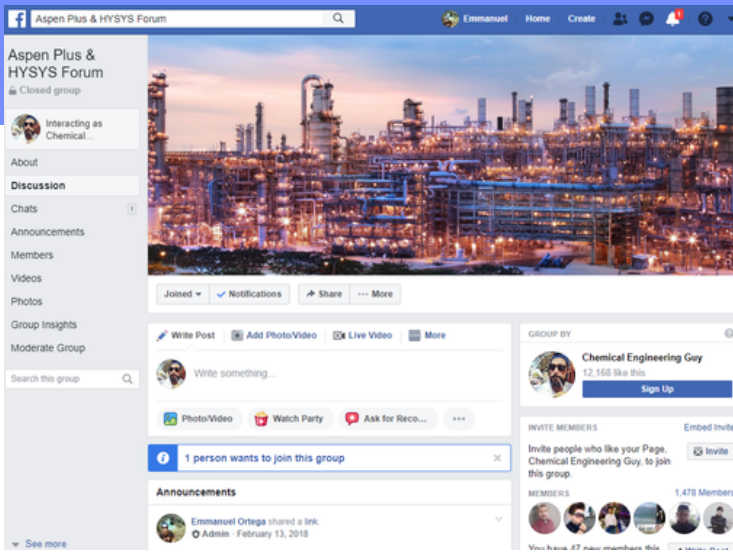

TIP 4

GETTING HELP ONLINE

The best way to get help is not reading the "help" guide!

Its going online!

Check out the communities!

My top pick:

Aspen Plus &
HYSYS Forum

Aspen Plus & HYSYS Forum

Aspen Plus & HYSYS Forum
Closed group

Interacting as Chemical...

About

Discussion

Chats 1

Announcements

Members

Videos

Photos

Group Insights

Moderate Group

Search this group

Shortcuts

- Aspen Plus & HYSYS F...
- Aspen Plus & HYS... 20+
- Toastmasters TEC D... 5
- NXT Learning 20+
- Asamblea Unal Med... 18

See more

Diego Paulino
March 31 at 9:15 PM

Optimum Residence Time calculation for given Reactor in Aspen HYSYS.

Like Comment

You, Ali Hashem, Mohamed Meziani and 40 others

16 Comments

Aspen Plus & HYSYS Forum

Aspen Plus & HYSYS Forum
Closed group

Interacting as Chemical...

About

Discussion

Chats 1

Announcements

Members

Videos

Photos

Group Insights

Moderate Group

Search this group

Shortcuts

- Aspen Plus & HYSYS F...

Emmanuel

Diego Paulino replied · 1 Reply · 5 hrs

Write a comment...

Yasir Shahzad shared a link.
13 hrs

FIVERR.COM
yasirshehzad0 : I will do process simulations on aspen hysys and chemcad for \$5 on www.fiverr.com

Samaphon Phromsamlee, Francis Antonio and 7 others

1 Comment

Like Comment

TIP 5

USEFUL SHORTCUTS!

✓ Geometry	✓ Process	✓ Errors & Warnings	✓ Run Status					
Calculation mode			Simulation		Recent			
Configuration								
TEMA Type	B -		E -		S -		BES	
Tube layout option	New (optimum) layout					New (optimum) layout		
Location of hot fluid	Shell side					Shell side		
Tube OD / Pitch	in	1	/	1.25	1	/	1.25	
Tube pattern	90-Square					90		
Tubes are in baffle window	Yes					Yes		
Baffle type	Single segmental					Unbaffled		
Baffle cut orientation	Horizontal							
Default exchanger material	Carbon Steel		1		Carbon Steel			
Size								
Specify some sizes for Design	Set default							
Shell ID / OD	in	23.25	/	24	23.25	/	24	
Tube length	in	16					16	
Baffle spacing center-center	in	4.65					4.65	
Number of baffles						0		
Number of tube / passes		75	/	6	75	/	6	
Shells in series	1					1		
Shells in parallel	1					1		
Overall Results								
Excess surface (%)						0		
Dp-ratio Shellside / Tubeside						0.0956	/	1.3086
Total cost (all shells)	Dollar(US)				21033			

TIP 5

USEFUL SHORTCUTS!

Manage Views	F3
Center View	CTRL+HOME
Page Break Preview	F2
Pan	CTRL+F3
Print	CTRL+P
Reset Page Breaks	SHIFT+F2
Select All	CTRL+A
Zoom to Fit	HOME
Zoom In	SHIFT+PAGE UP or CTRL+UP ARROW
Zoom in by small steps	PAGE UP or mouse wheel up
Zoom Out	SHIFT+PAGE DOWN or CTRL+DOWN ARROW
Zoom out by small steps	PAGE DOWN or mouse wheel down

Item	Shortcut Key
Check Results	CTRL+F8
Reinitialize	SHIFT+F5
Run	F5
Settings	CTRL+F7
Step	CTRL+F5

Item	Shortcut Key
Align Blocks	CTRL+B
Change Section	CTRL+F11
Change Stream Class	CTRL+Q
Exchange Icons	CTRL+K
Find Object	CTRL+F
Flowsheet Sections	F11
Hide/Show Annotation	CTRL+ALT+L
Hide/Show Connections	CTRL+ALT+C
Hide/Show Global Data	CTRL+ALT+G
Hide ID	CTRL+H
Hide/Show Measurements	CTRL+ALT+M
Move Blocks or Streams	Arrow keys
Reroute Streams	CTRL+J
Undo a change	CTRL+Z
Redo an undone change	CTRL+Y

MOST COMMON & USEFUL!

LEARN THEM, USE THEM!

TIP 6 - HIERARCHY LEVELS

Have a Repeating Process?

Hate repeating the flowsheeting?

Can't simply copy & paste it?

Use hierarchy BLOCK!

Step 1 - Build "Child" Process

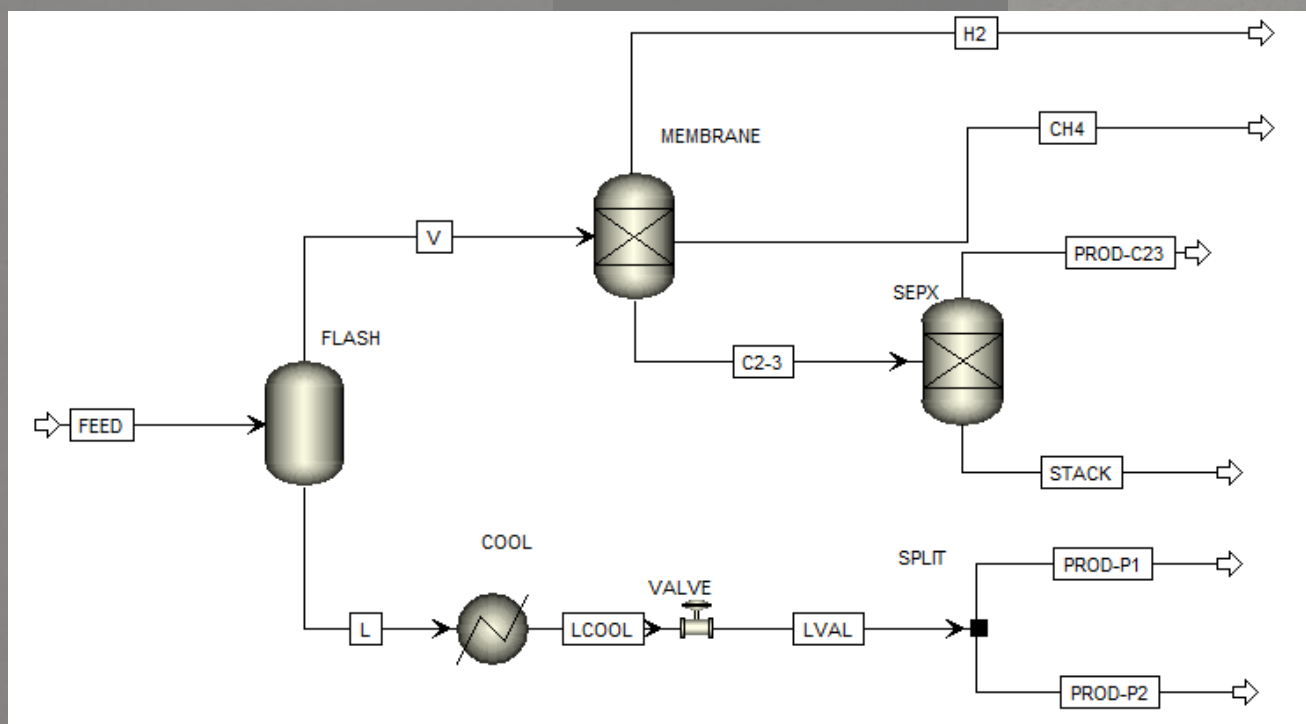

Step 2 - Select the hierarchy Block

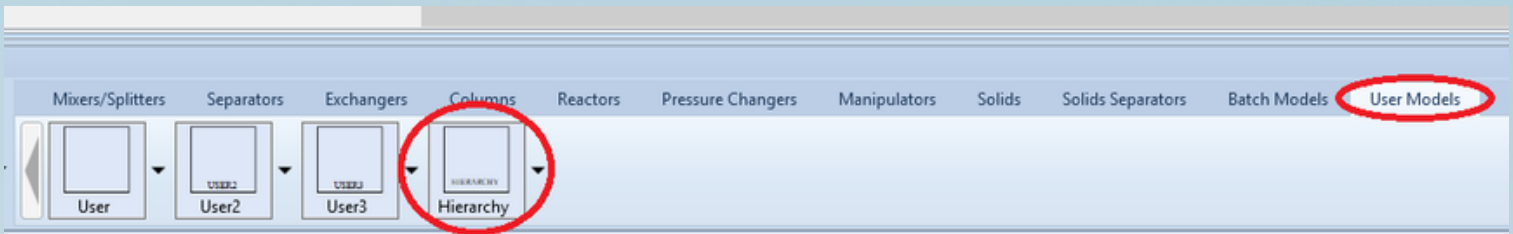

Step 3 - Build the "Child" Process

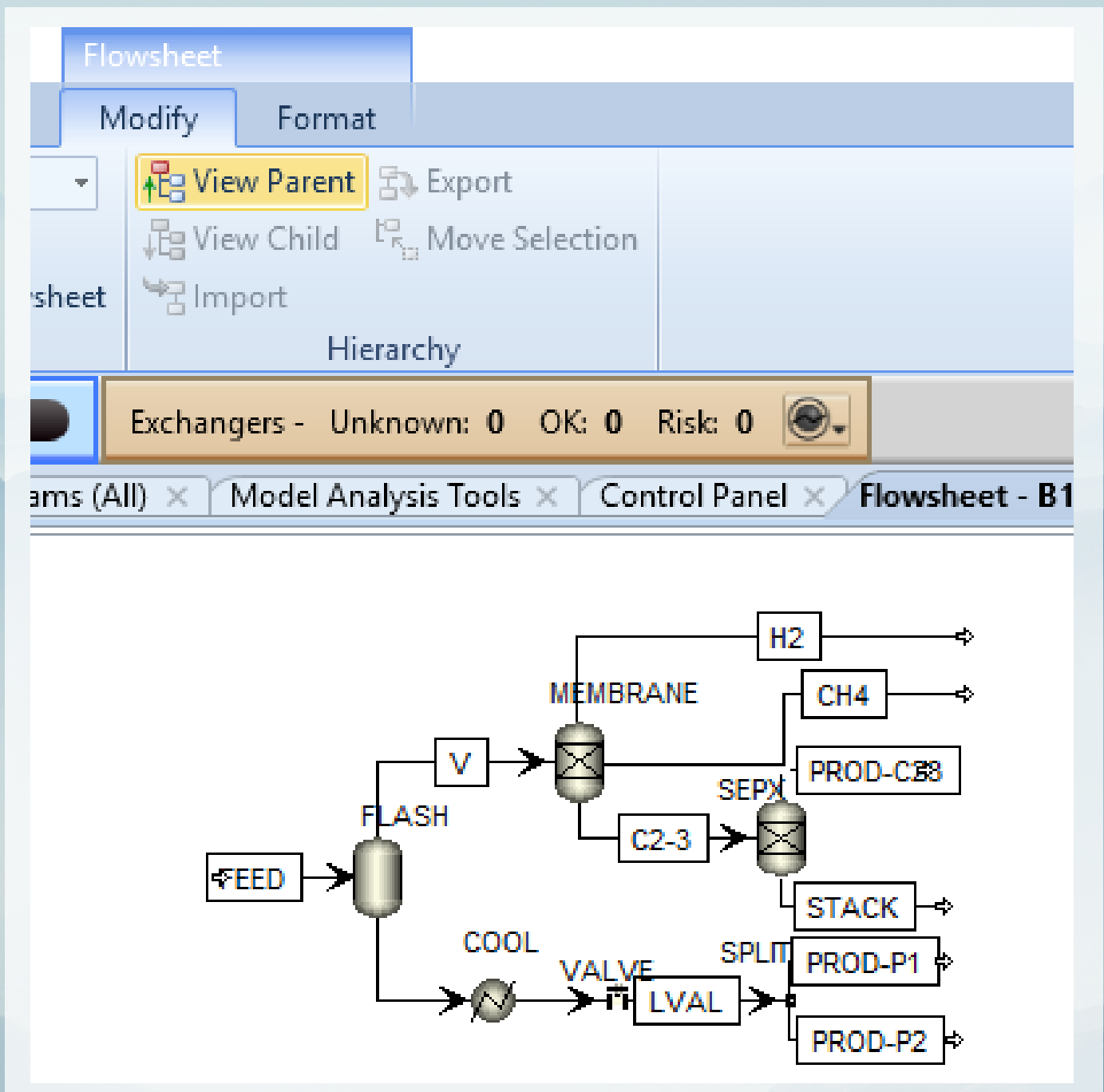

Step 4 - Connect Streams from Parent

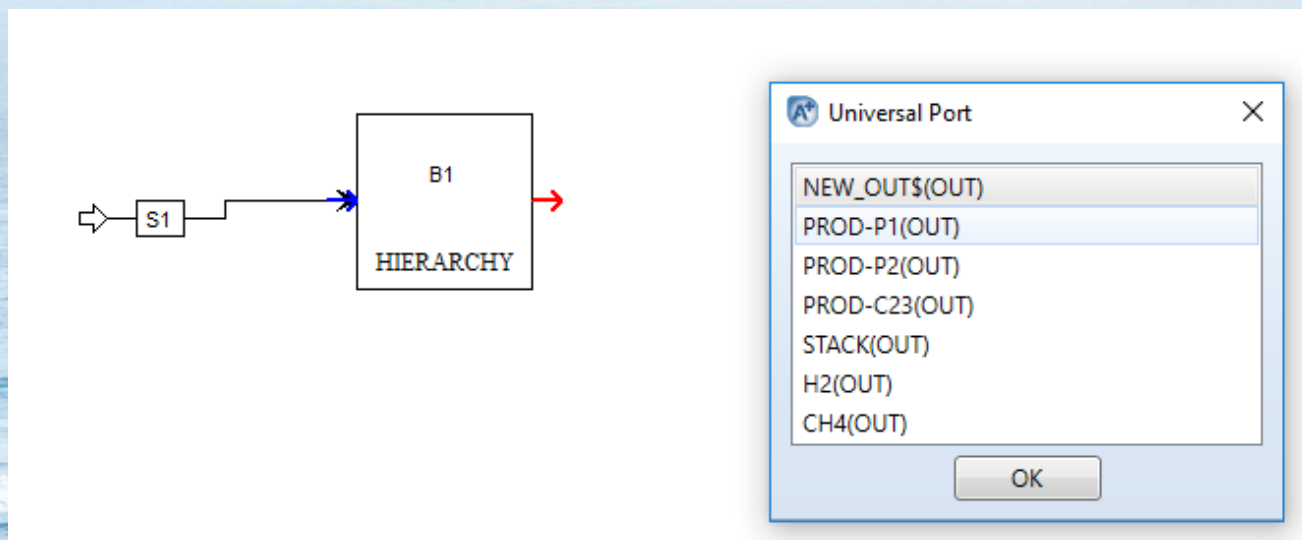

Step 5 - Verify Parent / Child

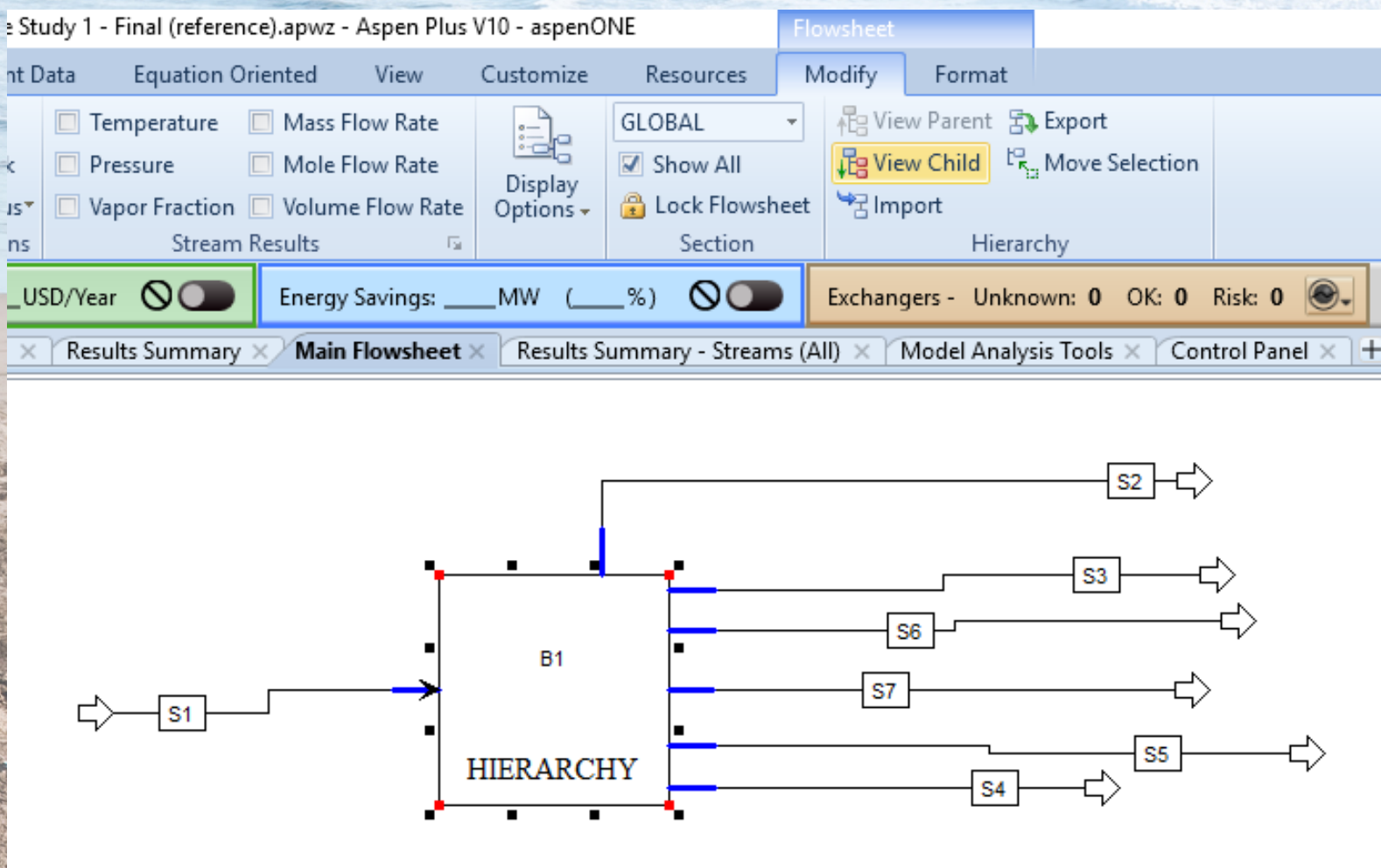

Master Hierarchy Levels HERE



TIP 7

PLOT, PLOT, PLOT

"FPE" TECHNIQUE

F*cking Plot Everything

Some Say:

"A photo says a thousand words"

Well, then a Plot says a million photos!

Most of the Plots can be custom made:

You choose the "X-Axis"

You choose your "Y-Axis"

Plot intervals

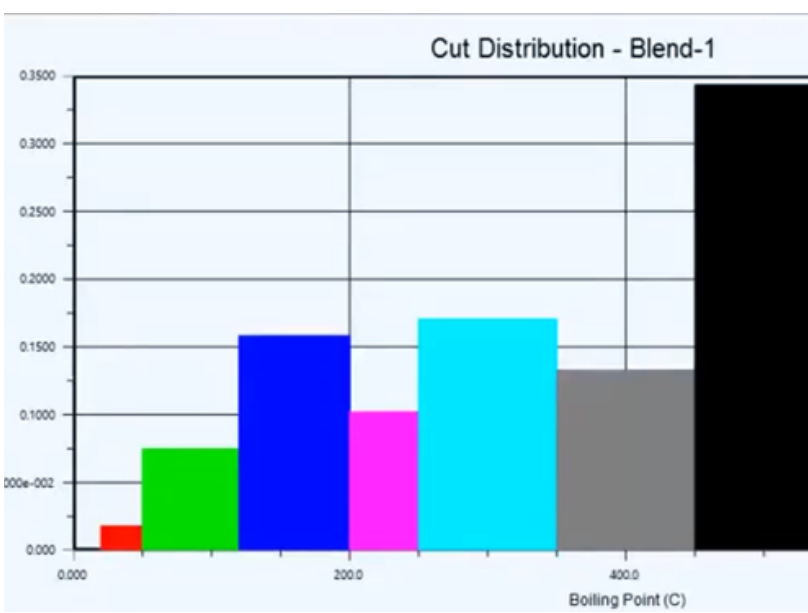
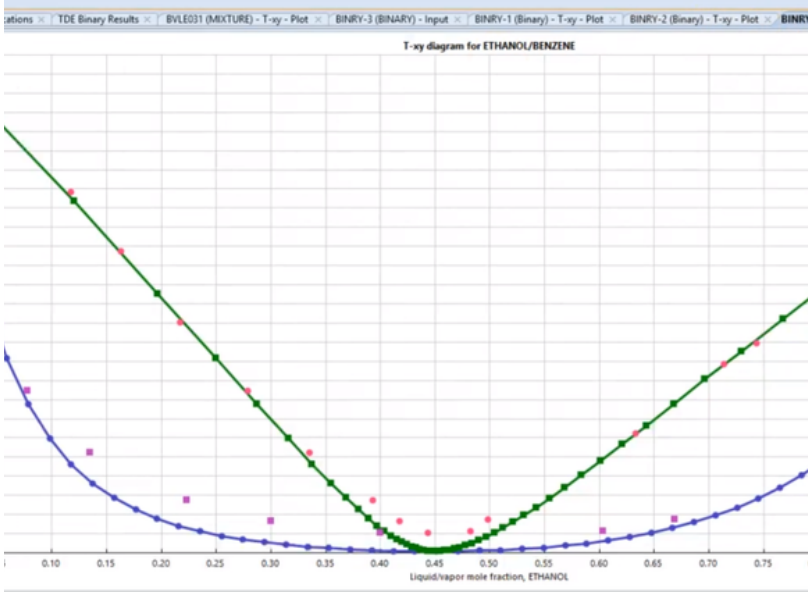
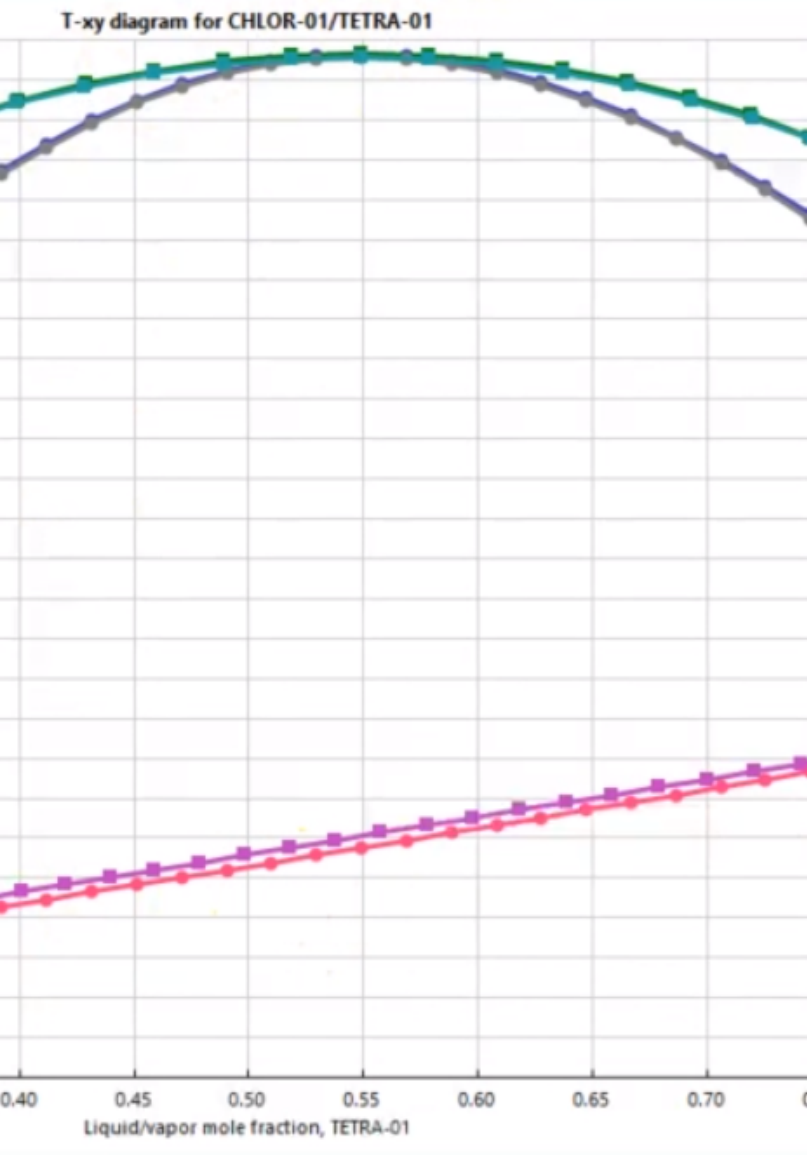

SOME USEFUL PLOTS:

- *Binary T vs. XY Diagrams*
- *Binary P vs. XY Diagrams*
- Regression & Data
- *Ternary Properties*
- *Concentration, Vapor Quality, Temperature & Pressure Profiles*

- *Crude Oil Cuts*
- *Crude Oil Distribution*
- *Trays Performance*

BLOCKS WITH PLOTS:

- *Distillation Column*
- *Reactors*
- *Pumps & Compression*
- *Heat Exchangers*

EXPORT TO EXCEL

BETTER DATA MANIPULATION

- We all love (and hate...) Excel!
- It is an amazing tool which can facilitate our labor (or complex it 100x)
- All data can be exported from Aspen to Excel!

Step 1 - Select Workbook

The screenshot shows the Aspen HYSYS V10 interface with the 'Export' menu open. The 'Workbook' option is selected. Below the menu, a data table is visible, showing material streams and their properties.

Name	Crude Oil	FlashVapor	FlashLiquid	HotFlashLiquid	Crude Feed	Main Steam	Diesel Steam	AGO Steam	Off Gases
Vapour Fraction	0.2891	1.0000	0.0000	0.3994	0.6098	1.0000	1.0000	1.0000	1.0000
Temperature [F]	450.0	450.0	450.0	650.0	622.5	375.0	300.0	300.0	107.9
Pressure [psia]	75.00	75.00	75.00	65.00	65.00	150.0	50.00	50.00	19.70
Molar Flow [lbmole/hr]	6214	1796	4417	4417	6214	416.3	166.5	138.8	8.058e-004
Mass Flow [lb/hr]	1.282e+006	1.570e+005	1.125e+006	1.125e+006	1.282e+006	7500	3000	2500	4.168e-002
Liquid Volume Flow [barrel/day]	1.000e+005	1.462e+004	8.538e+004	8.538e+004	1.000e+005	514.6	205.8	171.5	4.712e-003
Heat Flow [Btu/hr]	-9.189e+008	-9.846e+007	-8.204e+008	-6.471e+008	-7.456e+008	-4.237e+007	-1.703e+007	-1.419e+007	-41.52

Step 2 - Select Tabs to Export

The screenshot shows the Aspen HYSYS V10 interface with the 'Export Pages To Excel' dialog box open. The dialog box has a table for selecting pages to export and an 'Export To Excel' button.

Pages for Export	Export
Material Streams	<input checked="" type="checkbox"/>
Compositions	<input checked="" type="checkbox"/>
Energy Streams	<input checked="" type="checkbox"/>

Excel Layout
Number of Columns: 50

Buttons: Select All, Deselect All, Export To Excel, Cancel

File Home Insert Page Layout Formulas Data Review View Add-ins Tell me

Cut Copy Paste Format Painter

Calibri 11 A⁺ A⁻ B I U

Wrap Text Merge & Center

Clipboard Font Alignment

Step 3 - Export Spreadsheet

	A	B	C	D	E	F	G	H	I	J
1		Unit	Crude Oil	FlashVapo	FlashLiquio	FlashLiqu	Crude Fee	Main Stean	iesel Stea	AGO Stean
2										
3	Mole Frac (Methane)		0.000285	0.000952	1.37E-05	1.37E-05	0.000285	0	0	0
4	Mole Frac (Ethane)		0.000626	0.002022	5.77E-05	5.77E-05	0.000626	0	0	0
5	Mole Frac (Propane)		0.008642	0.026746	0.001279	0.001279	0.008642	0	0	0
6	Mole Frac (i-Butane)		0.005454	0.016074	0.001135	0.001135	0.005454	0	0	0
7	Mole Frac (n-Butane)		0.019339	0.055841	0.004493	0.004493	0.019339	0	0	0
8	Mole Frac (H2O)		0	0	0	0	0	1	1	1
9	Mole Frac (NBP[0]13*)		0.044548	0.121314	0.013326	0.013326	0.044548	0	0	0
10	Mole Frac (NBP[0]29*)		0.051866	0.134995	0.018056	0.018056	0.051866	0	0	0
11	Mole Frac (NBP[0]49*)		0.047894	0.116744	0.019891	0.019891	0.047894	0	0	0
12	Mole Frac (NBP[0]69*)		0.046526	0.103544	0.023336	0.023336	0.046526	0	0	0
13	Mole Frac (NBP[0]86*)		0.053297	0.106757	0.031554	0.031554	0.053297	0	0	0
14	Mole Frac (NBP[0]108*)		0.044434	0.075965	0.03161	0.03161	0.044434	0	0	0
15	Mole Frac (NBP[0]126*)		0.046245	0.067026	0.037792	0.037792	0.046245	0	0	0
16	Mole Frac (NBP[0]146*)		0.043005	0.050822	0.039826	0.039826	0.043005	0	0	0
17	Mole Frac (NBP[0]165*)		0.039231	0.036491	0.040345	0.040345	0.039231	0	0	0
18	Mole Frac (NBP[0]185*)		0.036629	0.025885	0.040999	0.040999	0.036629	0	0	0
19	Mole Frac (NBP[0]204*)		0.035532	0.018421	0.042491	0.042491	0.035532	0	0	0
20	Mole Frac (NBP[0]224*)		0.038161	0.013989	0.047992	0.047992	0.038161	0	0	0
21	Mole Frac (NBP[0]243*)		0.042241	0.010665	0.055083	0.055083	0.042241	0	0	0
22	Mole Frac (NBP[0]262*)		0.041197	0.006995	0.055108	0.055108	0.041197	0	0	0
23	Mole Frac (NBP[0]281*)		0.036344	0.004029	0.049487	0.049487	0.036344	0	0	0
24	Mole Frac (NBP[0]301*)		0.032033	0.002245	0.044149	0.044149	0.032033	0	0	0
25	Mole Frac (NBP[0]320*)		0.027976	0.001211	0.038862	0.038862	0.027976	0	0	0
26	Mole Frac (NBP[0]340*)		0.024144	0.000626	0.033709	0.033709	0.024144	0	0	0
27	Mole Frac (NBP[0]359*)		0.021395	0.000323	0.029966	0.029966	0.021395	0	0	0
28	Mole Frac (NBP[0]378*)		0.019153	0.000164	0.026875	0.026875	0.019153	0	0	0
29	Mole Frac (NBP[0]398*)		0.01688	7.98E-05	0.023712	0.023712	0.01688	0	0	0
30	Mole Frac (NBP[0]417*)		0.015142	3.82E-05	0.021286	0.021286	0.015142	0	0	0

TIP 9

SENSITIVITY ANALYSIS

Ever wonder what will happen if T1 changes from 25°C to 50°?
to 55°
to 100°
or to 120°?

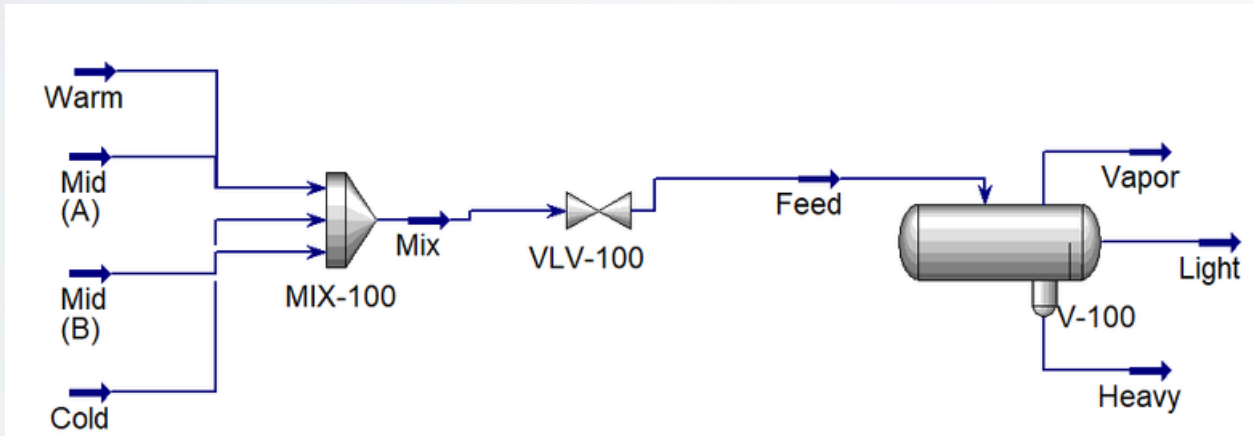

Simulate individually...
Nah... too much time!
...You get the point...

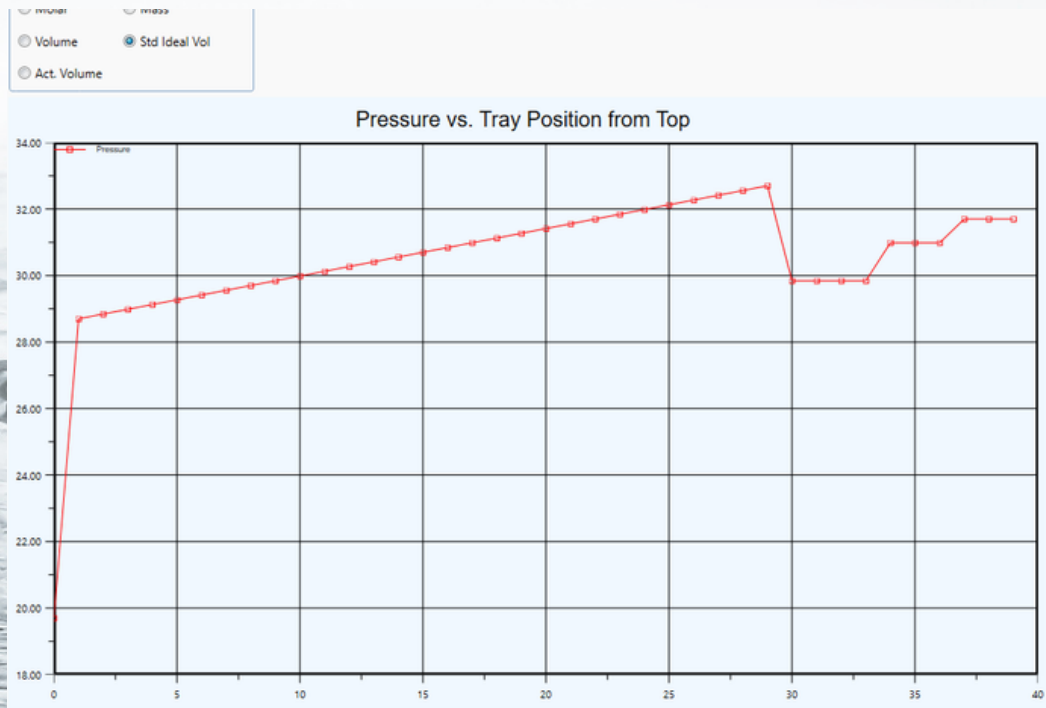

USE CASE STUDIES / SENSITIVITY ANALYSIS

Step 1 - Set Variable to "VARY"

Model Analysis Tools | HEAT2 (Heater) | COL2 (RadFrac) | COL (RadFrac) | R-1 (POWERLAW) | PFR (

Vary Define Tabulate Options Cases Fortran Declarations Comments

Active Case study

Manipulated variables (drag and drop variables from form to the grid below)

Variable	Active	Manipulated variable	Units
1	<input checked="" type="checkbox"/>	Stream-Var Stream=FEED Substream=MIXED Variable=MOLE-FLOW	kmol/hr

New Delete Copy Paste

Edit selected variable

Manipulated variable

Variable: 1
Type: Stream-Var
Stream: FEED
Substream: MIXED
Variable: MOLE-FLOW
Units: kmol/hr

Manipulated variable limits

Equidistant Logarithmic List of values

Start point: 210 kmol/hr
End point: 500 kmol/hr
Number of points: 291
Increment: 1 kmol/hr

Report labels

Step 2 - Define OUTPUT

Model Analysis Tools | HEAT2 (Heater) | COL2 (RadFrac) | COL (RadFrac) | R-1 (POWERLAW) | PFR (

Vary Define Tabulate Options Cases Fortran Declarations Comments

Sampled variables (drag and drop variables from form to the grid below)

Variable	Definition
CUMPUR	Mole-Frac Stream=CUMENE Substream=MIXED Component=CUMENE
CUMFLOW	Mole-Flow Stream=CUMENE Substream=MIXED Component=CUMENE Units=kmol/hr

New Delete Copy Paste Move Up Move Down

Edit selected variable

Variable: CUMPUR

Reference: Mole-Frac

Type: Mole-Frac
Stream: CUMENE
Substream: MIXED
Component: CUMENE

Category

All
 Blocks
 Streams
 Model Utility
 Property Parameters
 Reactions

Step 3 - Tabulate

S-1 (SENSITIVITY) - Results Curve - Plot | Main Flowsheet | S-1 (SENSITIVITY)

Summary Define Variable Status

Row/Case	Status	VARY 1 FEED MIXED TOTAL MOLEFLOW KMOL/HR	CUMPUR	CUMFLOW KMOL/HR
31	OK	240	0.990761	54.1055
32	OK	241	0.991139	55.911
33	OK	242	0.991495	57.7257
34	OK	243	0.991832	59.5496
35	OK	244	0.99215	61.3827
36	OK	245	0.992452	63.2246
37	OK	246	0.992738	65.0753
38	OK	247	0.993009	66.9342
39	OK	248	0.993267	68.801
40	OK	249	0.993512	70.6749
41	OK	250	0.993745	72.5551
42	OK	251	0.993967	74.4404
43	OK	252	0.994179	76.3293
44	OK	253	0.99438	78.2197
45	OK	254	0.994572	80.1174
46	OK	255	0.994756	82.0126
47	OK	256	0.994928	83.8794
48	OK	257	0.995092	85.7445
49	OK	258	0.995247	87.5761
50	OK	259	0.995393	89.388
51	OK	260	0.995529	91.1464

Step 4 - Graph Results

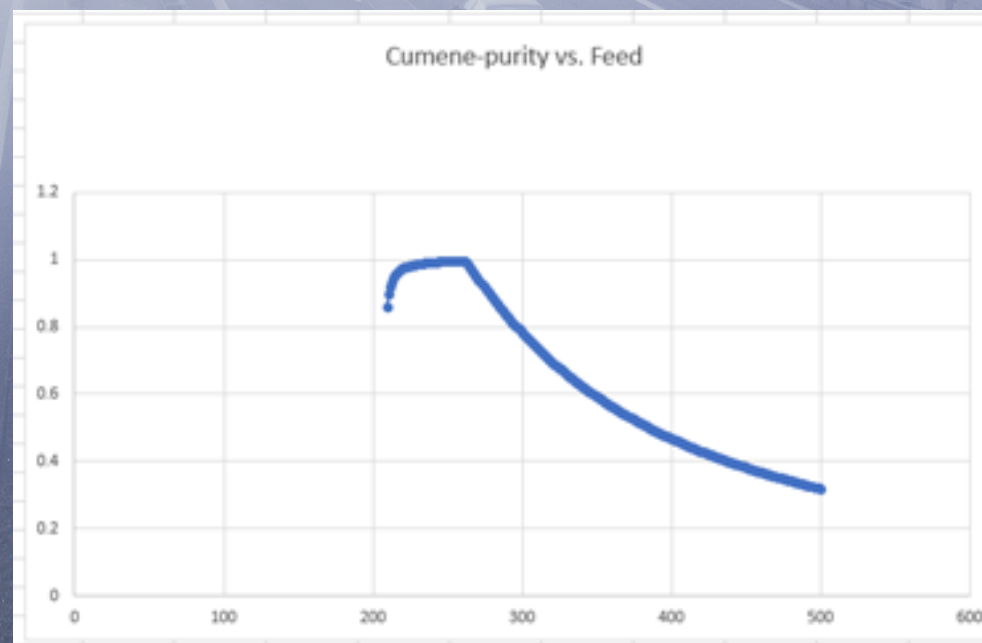

Learn More --> [Sensitivity Analysis Here...](#)

TIP 10 - BE PATIENT!

As any skill, learning to simulate processes will take **TIME!**

Be patient! But **WORK!**

Work in different:

- Processes
- Workshops
- Industries
- Companies
- Unit Operations
- Courses



***disciplines &
intent will make
you learn!***



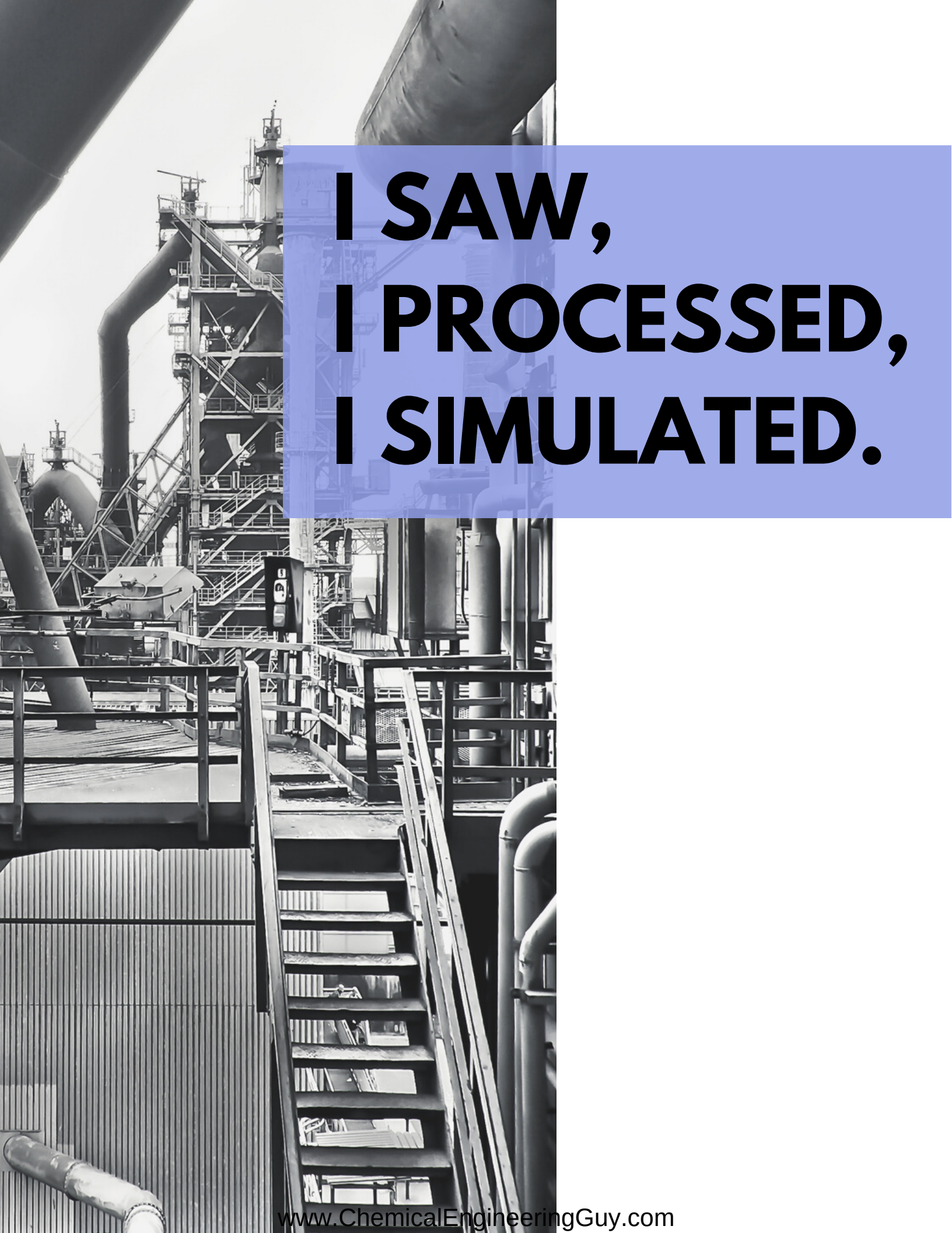

**I SAW,
I PROCESSED,
I SIMULATED.**

FINAL NOTES

EMMANUEL ORTEGA
AKA
CHEMICAL ENGINEERING GUY



I hope you enjoyed this simple tricks and tips!

They will help you improve your simulation procedures!

Remember that in order to improve yourself, YOU need to put the hard work in!

Nobody is going to learn for you!

Keep it up guys! I wish you the best of EPIC SIMULATIONS!



Contact me: [Hello@ChemicalEngineeringGuy.com](mailto>Hello@ChemicalEngineeringGuy.com)

SURPRISES!



GET THE COURSES!

Aspen Plus Basic Modeling



Aspen Plus Physical Properties



Aspen Plus Intermediate Modeling



Aspen Plus Bootcamp: 12 Case Studies



GET THE COURSES!

Aspen HYSYS Basic Modeling



Aspen HYSYS Petroleum Assays and Oil Characterization

